

2.5Gbps 1550nm 40km SFP Optical Transceiver Module

S-SP2G55L40-xD

Features

- Hot-pluggable
- 2.5Gbps operation
- +3.3V single power supply
- High-performance and cost-effective
- 1550nm LD and PIN photodetector for 40km trans-mission
- Compliant with SFP MSA and SFF-8472 with duplex LC receptacle
- Digital Diagnostic Monitoring
- Compatible with SONET OC-48
- Operating case temperature: 0 to +70°C
-40 to +85°C
- RoHS compliant (lead free)

Applications

- SDH STM-16 and SONET OC-48 system
- 2X Fiber Channel
- Gigabit Fiber Channel
- Switch to Switch interface
- Switched backplane applications
- Router/Server interface
- Other optical transmission systems

Description

SFP transceivers are high performance, cost effective modules supporting 2.5Gbps and 40km transmission distance with SMF.

The transceiver consists of three sections: a 1550nm LD transmitter, a PIN photodiode integrated with a trans-impedance preamplifier (TIA). SFP modules satisfy class I laser safety requirements.

The transceivers are compatible with SFP Multi-Source Agreement (MSA) and SFF-8472. For further information, please refer to SFP MSA.

Absolute Maximum Ratings

Parameter	Symbol	Min	Typ	Max	Unit
Power Supply Voltage	V _{cc}	-0.5		4	V
Storage Temperature Range	T _s	-40		85	°C
Relative Humidity - Storage	RH _s	0		95	%
Relative Humidity - Operating	RH _o	0		85	%

2.5Gbps 1550nm 40km SFP Optical Transceiver Module

S-SP2G55L40-xD

Recommended Operating Conditions

Parameter	Symbol	Min	Typ	Max	Unit
Case Operating Temperature Range	T _C	0	-	70	°C
		-40	-	85	
Power Supply Voltage	V _{CC}	3.14	3.3	3.47	V
Supply Current	I _{CC}	-	-	300	mA
Data Rate	BR	-	2.5	-	Gbps

Electrical Characteristics

Transmitter Electrical Characteristics					
Parameter	Symbol	Min	Typ	Max	Unit
Differential Input Voltage Swing	V _{IN}	400	-	2000	mV
Tx Differential Input Impedence	Z _{IN}	-	100	-	Ω
Transmitter Disable Voltage	V _{DIS}	2.0	-	V _{CC} +0.3	V
Transmitter Enable Voltage	V _{EN}	0	-	0.8	V
T _{FAULT} Logic High	V _{TFH}	2.4	-	V _{CC}	V
T _{FAULT} Logic Low	V _{TFL}	V _{EE}	-	V _{EE} +0.4	V
Receiver Electrical Characteristics					
Parameter	Symbol	Min	Typ	Max	Unit
Differential output Voltage Swing	V _{OUT}	400	-	1000	mV
Rx Differential Output Impedence	Z _{OUT}	-	100	-	Ω
LOS Assert Voltage	V _{LOSA}	2.4	-	V _{CC}	V
LOS De-assert Voltage	V _{LOSD}	V _{EE}	-	V _{EE} +0.4	V

Optical Characteristics

Transmitter Characteristics						
Parameter	Symbol	Min	Typ	Max	Unit	Notes
Laser Type		LD				
Data Rate	-	-	2.5	-	Gb/s	
Center Wavelength Range	λ	1500	1550	1580	nm	
Spectral Width@-20dB	Δλ	-	-	1	nm	
Average Launch power of OFF transmitter	P _{OFF}	-	-	-40	dBm	
Launch Optical Power	P _{out}	-5	-	0	dBm	1
Extinction Ratio	ER	8.2	-	-	dB	

2.5Gbps 1550nm 40km SFP Optical Transceiver Module

S-SP2G55L40-xD

Receiver Characteristics						
Receiver Type			PIN			
Data Rate	-	-	2.5	-	Gb/s	
Operating Central Wavelength	λ	1260	-	1610	nm	
Receiver Sensitivity (OMA)	Sen	-	-	-17	dBm	2
Receiver Overload	P_{SAT}	0	-	-	dBm	
LOS Assert	LOSA	-35	-	-	dBm	
LOS De-Assert	LOSD	-	-	-17	dBm	
LOS Hysteresis	LOSH	0.5	3	5	dB	
Notes						
1. The optical power is launched into SMF. 2. Measured with 223-1 PRBS@2.5Gbps, BER<10 ⁻¹²						

General Specifications

Parameter	Symbol	Min	Typ	Max	Unit	Notes
Bit Rate	BR	-	2.5	-	Gb/s	
Bit Error Ratio	BER	-	-	10 ⁻¹²		

Pin Definitions

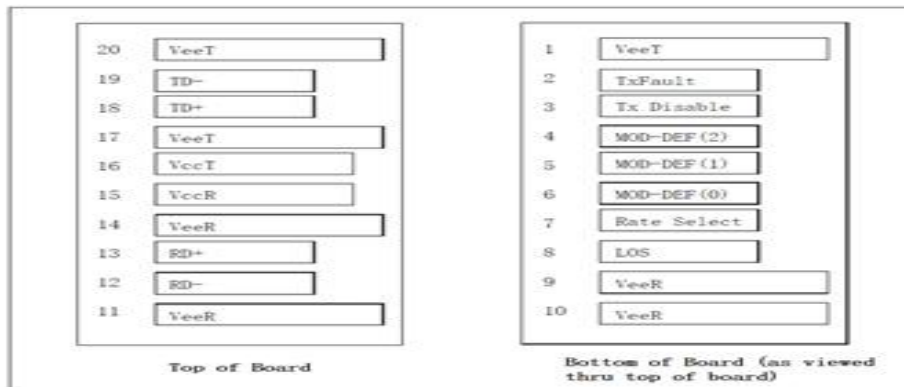

PIN Assignment			
PIN	Symbol	Description	Notes
1	V _{EET}	Transmitter Ground	
2	Tx_FAULT	Transmitter Fault	1
3	Tx_DIS	Transmit Disable	1
4	MOD_DEF 2	Serial Data	1

2.5Gbps 1550nm 40km SFP Optical Transceiver Module

S-SP2G55L40-xD

5	MOD_DEF 1	Clock Signal	1
6	MOD_DEF 0	Interface Digital Ground	
7	Rate Select	Not Connected	
8	Rx_LOS	Receiver Loss of Signal	1
9	V _{EER}	Receiver Ground	
10	V _{EER}	Receiver Ground	
11	V _{EER}	Receiver Ground	
12	RD-	Rx_Data Output (Inverted)	
13	RD+	Rx_Data Output (Non Inverted)	
14	V _{EER}	Receiver Ground	
15	V _{CCR}	Receiver DC Power	
16	V _{CCT}	Transmitter DC Power	
17	V _{EET}	Transmitter Ground	
18	TD+	Tx_Data Input (Non Inverted)	
19	TD-	Tx_Data Input (Inverted)	
20	V _{EET}	Transmitter Ground	

Notes

1. The uncommitted Tx_Fault, Rx_LOS, MOD_DEF 1 and MOD_DEF 2 LVTTTL monitor and control pins each require a pull up resistor of 4.7k to 10k Ohms on the host board.

Recommended Interface Circuit

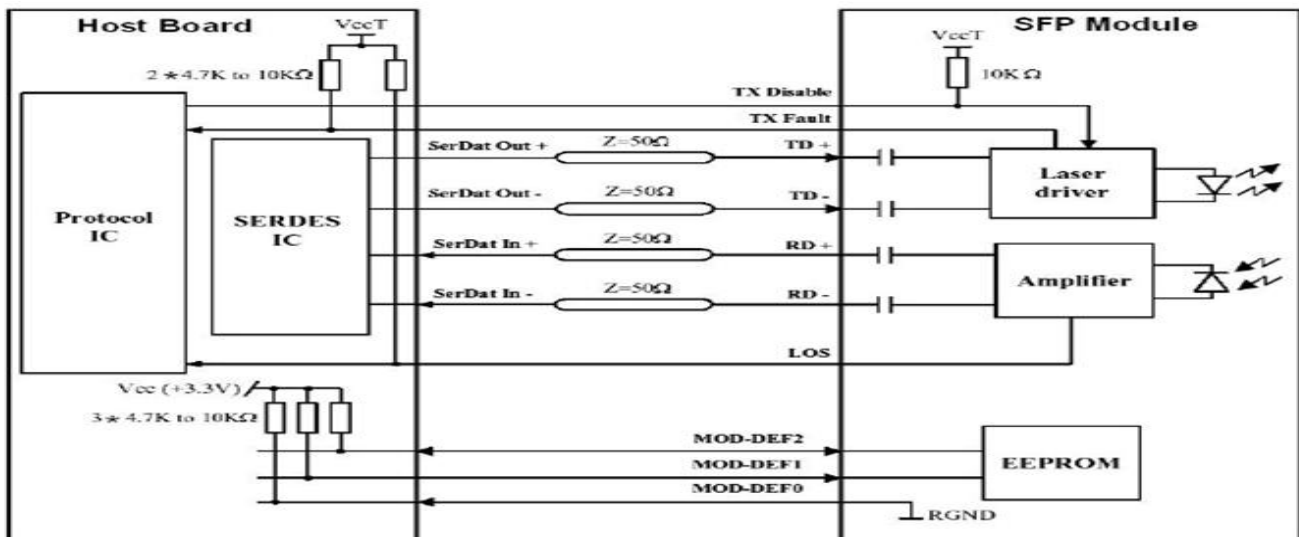

2.5Gbps 1550nm 40km SFP Optical Transceiver Module

S-SP2G55L40-xD

Mechanical Dimensions

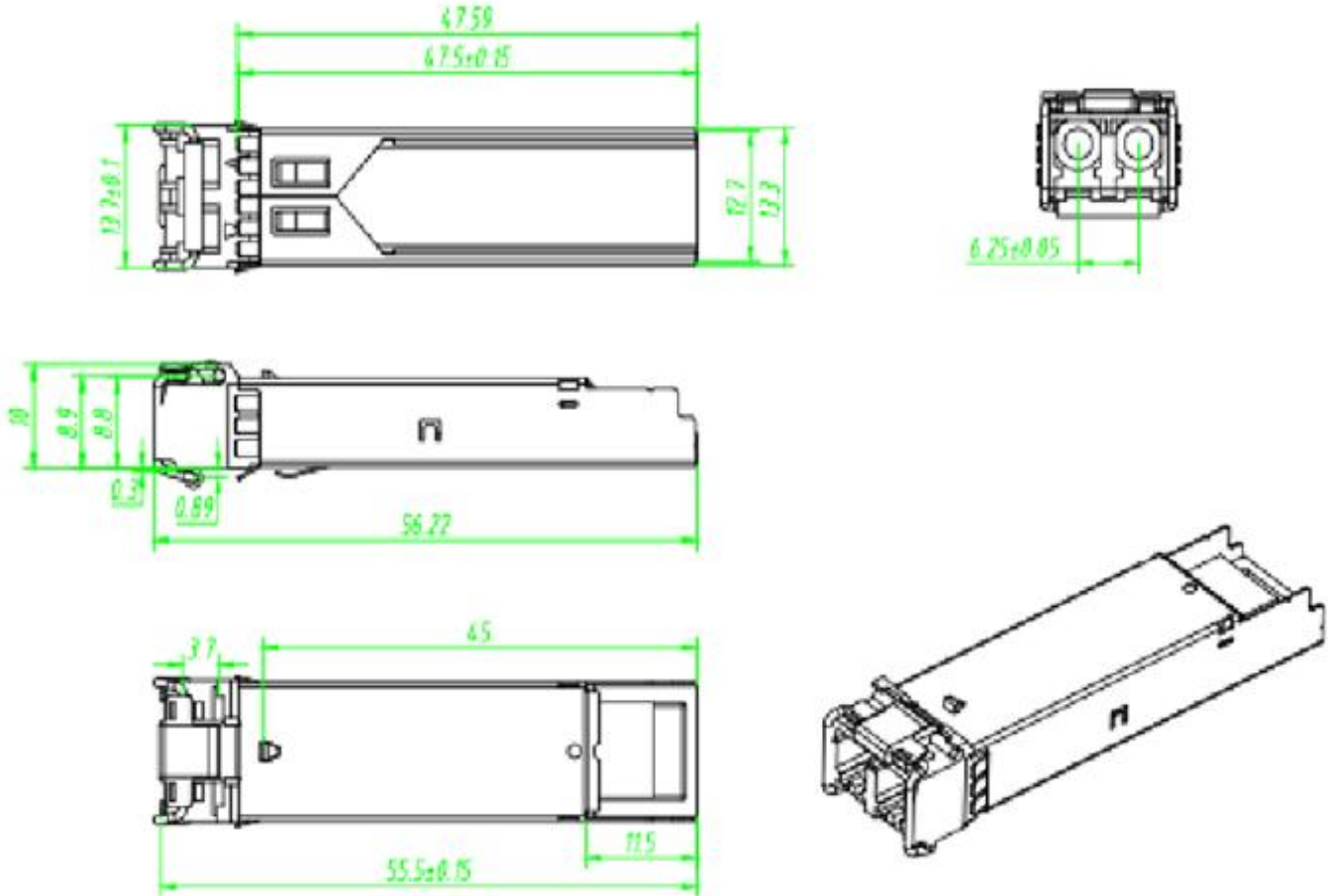

Ordering information

Part Number	Product Description
S-SP2G55L40-CD	SFP, 2.5Gbps, 1550nm, SM, 40km, 0°C~+70°C, With DDM
S-SP2G55L40-ID	SFP, 2.5Gbps, 1550nm, SM, 40km, -40°C~+85°C, With DDM