

1.25Gbps DWDM C17~C61 80km SFP Optical Transceiver Module

S-SD1GDWL80-CD-xx

Features

- Wavelength selectable to C-band and L-band ITU-T grid wavelengths
- 1.25Gbps operation
- Suitable for use in 100GHz channel spacing DWDM systems
- DWDM DFB and APD photodetector for 80km trans-mission
- Compliant with DWDM SFP MSA with duplex LC receptacle
- Digital Diagnostic Monitoring
- Cold Start up Wavelength Compliance
- Operating case temperature:0 to +70°C
- RoHS compliant (lead free)

Applications

- SFP Transceivers for DWDM SONET/ SDH
- Ethernet IEEE 802.3ae
- Fiber Channel

Description

DWDM SFP Transceiver exhibits excellent wavelength stability, supporting operation at 100 GHz channel, cost effective module. It is designed for DWDM SONET/ SDH, Gigabit Ethernet and Fiber- Channel applications.

The transceiver consists of two sections: The transmitter section incorporates a colded DFB laser. And the receiver section consists of an APD photodiode integrated with a TIA. DWDM SFP modules satisfy class I laser safety requirements.

DWDM SFP transceiver provides an enhanced monitoring interface, which allows real-time access to device operating parameters such as transceiver temperature, laser bias current, transmitted optical power, received optical power and transceiver supply voltage, laser temperature and TEC current.

Absolute Maximum Ratings

Parameter	Symbol	Min	Typ	Max	Unit
Power Supply Voltage	Vcc	-0.3		4	V
Storage Temperature Range	Ts	-40		85	°C
Relative Humidity - Storage	RH _s	0		95	%
Relative Humidity - Operating	RH _o	0		85	%

1.25Gbps DWDM C17~C61 80km SFP Optical Transceiver Module

S-SD1GDWL80-CD-xx

Recommended Operating Conditions

Parameter	Symbol	Min	Typ	Max	Unit
Case Operating Temperature Range	T _c	-5	-	70	°C
Power Supply Voltage	V _{cc}	3.14	3.3	3.47	V
Supply Current	I _{cc}	-	-	380	mA

Transmitter Specifications – Optical

Parameter	Symbol	Min	Typical	Max	Unit
Data Rate Multirate	Mra	155	1250	2667	Mbps
Center Wavelength (SOL)△	c	c -25	c	c +25	pm
Center Wavelength (EOL)▲	c	c -100	c	c+100	pm
Optical Transmit Power	P _o	0	-	5	dBm
Side Mode Suppression Ratio	SMSR	30	-	-	dB
Optical Transmit Power (disabled)	PTX_DISABLE	-	-	-40	dBm
Extinction Ratio	ER	8.2	-	-	dB
Channel Spacing	Δf	-	100	-	GHz
Jitter Generation	TJP-P	-	-	70	mUI
Spectral Width (-20dB)	DI20	-	0.1	0.3	nm
Eye Mask	Compliant with Bell core GR-253-CORE & ITU G.957 for SONET/SDH and with IEEE 802.3ae for Ethernet and Fibre Channel				

Transmitter Specifications – Electrical

Parameter	Symbol	Min	Typical	Max	Unit
Supply Voltage	V _{ccTX}	3.13	3.3	3.47	V
PECL/CML Input	V _{txDIFF}	500	-	1600	mV
Input Rise/Fall	TR / TF	-	-	160	ps
TX-Fault Fault	V _f	2	-	V _{cc}	V
TX-Fault Normal	V _n	V _{ee}	-	V _{ee} +0.5	V
TX_DISABLE(asserted)	VDH	2	-	V _{cc}	V
TX_DISABLE (negated)	VDL	V _{ee}	-	V _{ee} +0.8	V

1.25Gbps DWDM C17~C61 80km SFP Optical Transceiver Module

S-SD1GDWL80-CD-xx

APD Receiver Specifications – Optical

Parameter	Symbol	Min	Typical	Max	Unit
Receiver Sensitivity(OC24)	Rsens-1	-	-30	-28	dBm
Receiver Sensitivity(OSNR = 20dB)	Rsens-2	-	-	-24	dBm
Maximum Input Power	RX-overload	-	-	-7	dBm
Input Operating Wavelength	λ	1528	-	1564	nm
Reflectance	Rrx	-	-	-24	dB
Loss of Signal Asserted		-40	-	-	dBm
LOS De-Asserted		-	-	-25	dBm
LOS Hysteresis		0.5	-	-	dB

APD Receiver Specifications – Electrical

Parameter	Symbol	Min	Typical	Max	Unit
Supply Voltage	VccRX	3.13	3.3	3.47	V
Differential Output Swing	Vout P-P	370	-	2000	mV
Rise/Fall Time	Tr / Tf	-	-	175	ps
Loss of Signal –Asserted	VOH	2	-	Vcc	V
Loss of Signal –Negated	VOL	Vee	-	Vee+0.5	V

Low Speed Electrical Signal Timings

Parameter	Symbol	Min	Typical	Max	Unit
TX Disable Negate Time	t-on	-	-	20	ms
TX Disable Assert Time	t-off	-	-	20	ms
Time to initialize, including reset of TX_FAULT	t_init	-	-	300	ms
Start-up Time	t_startup	-	-	90	s
TX_FAULT/INT Assert Time	t_fault	-	-	50	ms
TX_DISABLE to Reset	t_reset	10	-	-	ms
LOS Assert Time	t_los_on	-	-	100	us
LOS Negate Time	t_los_off	-	-	100	us
Serial ID Clock Rate	f_serial_clock	-	-	100	kHz

1.25Gbps DWDM C17~C61 80km SFP Optical Transceiver Module

S-SD1GDWL80-CD-xx

Pin Definitions

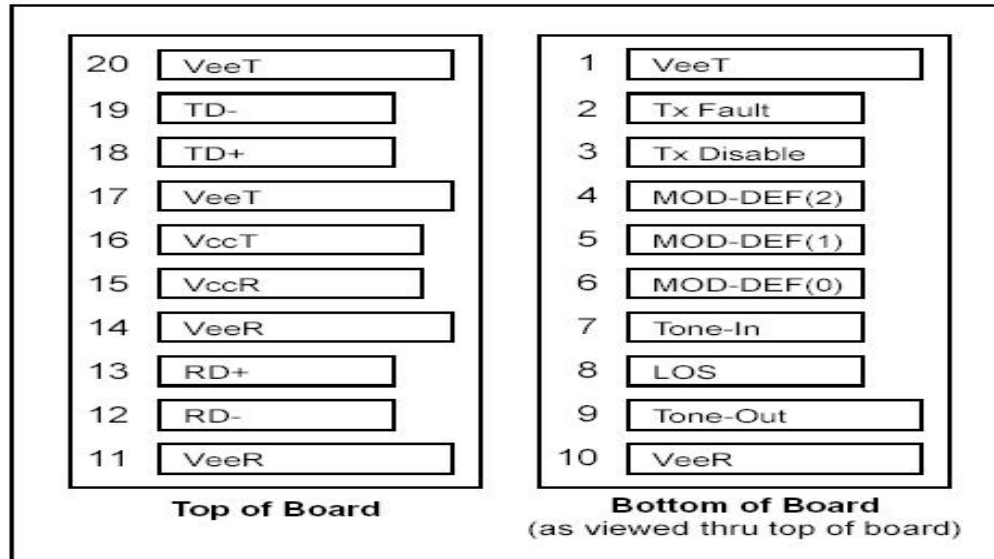

PIN Assignment			
Pin Number	Name	Function	Ref.
1	VEET	Transmitter Ground	
2	TX_FAULT/IN T	Transmitter Fault	1
3	TX_DISABLE	Transmitter Disable	2
4	MOD-DEF(2)	Module Definition 2	3
5	MOD-DEF(1)	Module Definition 1	3
6	MOD-DEF(0)	Module Definition 0	3
7	Tone in	Rate Select -Not Implemented	
8	LOS	Loss of Signal	4
9	VEER	Receiver Ground	
10	VEER	Receiver Ground	
11	VEER	Receiver Ground	
12	RD-	Inverted Received	
13	RD+	Received Data	
14	VEER	Receiver Ground	
15	VCCR	Receiver Power	
16	VCCT	Transmitter Power	
17	VEET	Transmitter Ground	

1.25Gbps DWDM C17~C61 80km SFP Optical Transceiver Module

S-SD1GDWL80-CD-xx

18	TD+	Transmit Data	
19	TD-	Inverted Transmit	
20	VEET	Transmitter Ground	

Notes

1. TX Fault is an open collector/drain output, which should be pulled up with a 4.7K – 10K. resistor on the host board. Pull up voltage between 2.0V and VccT, R+0.3V. When high, output indicates a laser fault of some kind. Low indicates normal operation. In the low state, the output will be pulled to < 0.8V.
2. TX disable is an input that is used to shut down the transmitter optical output. It is pulled up within the module with a 4.7 – 10 K. resistor.
3. These are the module definition pins. They should be pulled up with a 4.7K – 10K. resistor on the host board. The pull-up voltage shall be VccT or VccR (see Section IV for further details).
4. LOS (Loss of Signal) is an open collector/drain output, which should be pulled up with a 4.7K – 10K. resistor. Pull up voltage between 2.0V and VccT, R+0.3V. When high, this output indicates the received optical power is below the worst-case receiver sensitivity (as defined by the standard in use). Low indicates normal operation. In the low state, the output will be pulled to < 0.8V.

Recommended Interface Circuit

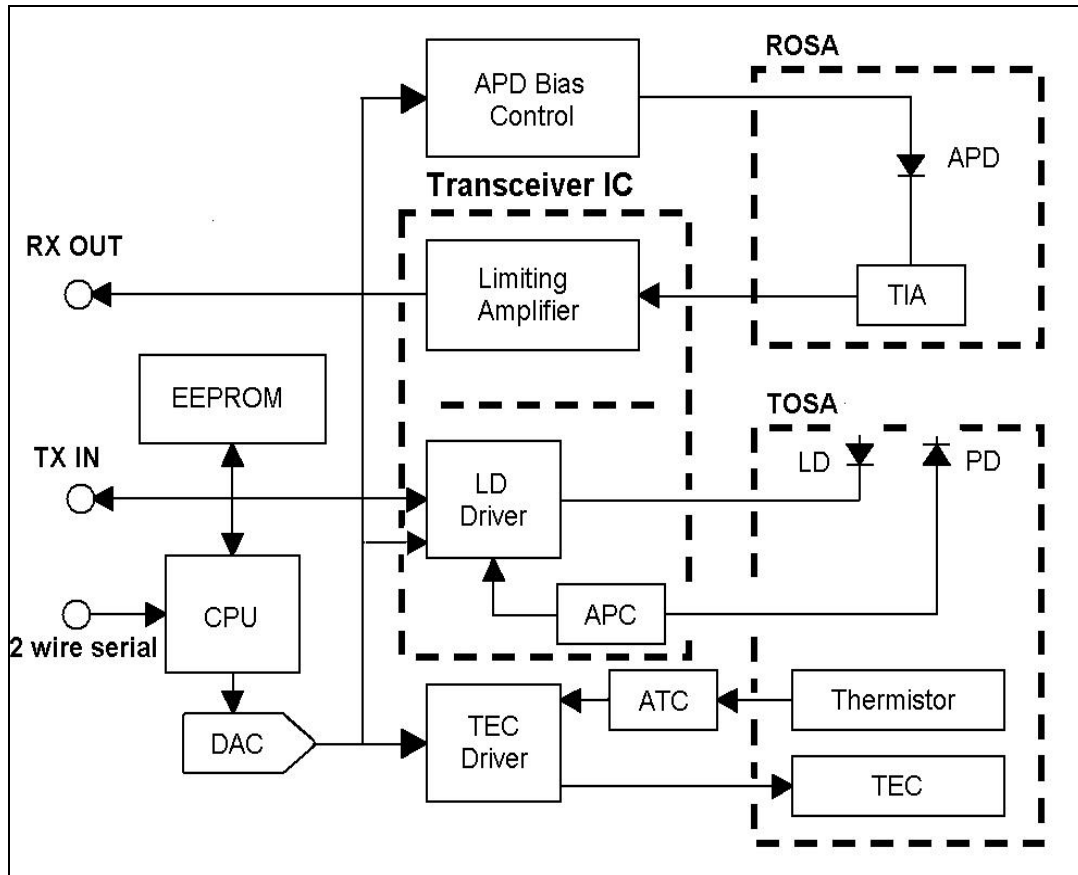

Block Diagram of DWDM-SFP.

1.25Gbps DWDM C17~C61 80km SFP Optical Transceiver Module

S-SD1GDWL80-CD-xx

Mechanical Dimensions

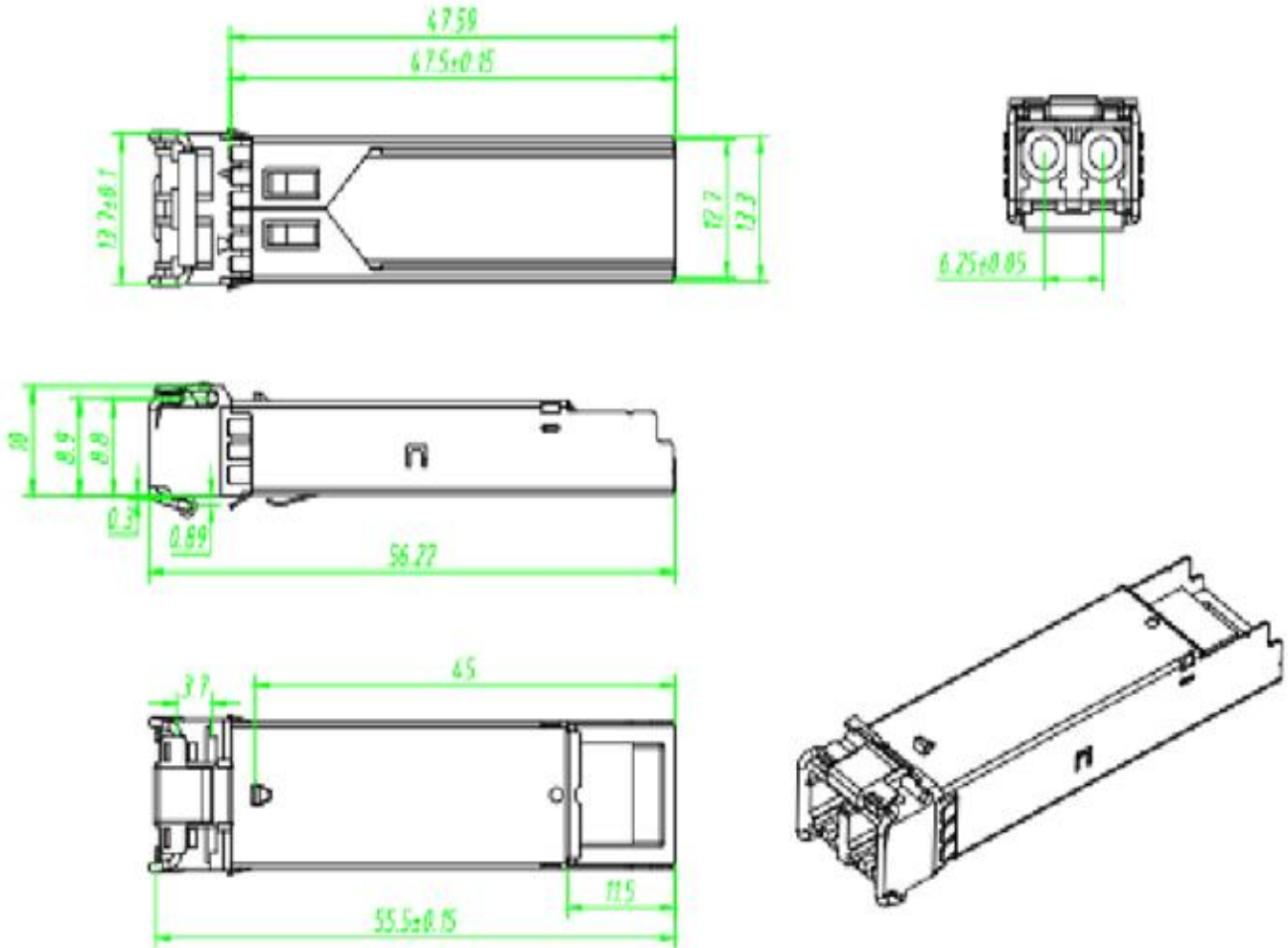

Ordering information

Part Number	Product Description
S-SD1GDWL80-CD-xx	SFP,DWDM 1.25Gbps,1510nm~1610nm, SM, LC,80km, 0°C~+70°C, With DDM
XX=17~61 (ITU Channel C-band) 62~16(ITU Channel L-band)	